

KTS

Fire Damper - round

Installation manual



TM **S M A Y**



Version 6.00

SMAY reserves the right to make changes to this document.

TABLE OF CONTENT

INSTALLATION TECHNOLOGY	2
I. INSTALLATION TECHNOLOGY - CEILING	3
II. INSTALLATION TECHNOLOGY – RIGID WALL	4
III. INSTALLATION TECHNOLOGY – FLEXIBLE WALL	6
IV. INSTALLATION TECHNOLOGY – HIGH WALL THICKNESS CONSTRUCTION.....	9
V. INSTALLATION TECHNOLOGY – INSTALLATION AWAY FROM WALL CONSTRUCTION (SILICATE BOARDS)	10

INSTALLATION TECHNOLOGY

Before installing the fire dampers, make sure that there are no damage, during transport or storage, that could block the baffle.

Check that the baffle can be opened and closed (full opening and closing position). To open fire dampers KTS-O-S use the actuator key.

The opening and closing must proceed smoothly (not stepwise).

Do not pull by baffle to open or close fire damper, it may cause permanent damage, not covered by the warranty.

During KTS-O-S damper test, to opening use a key, mounted on housing.

Before installing, secure the fire damper, by dust and dirt, using a foil or other screening material. It can prevent components of fire damper by damage.

Dampers to preserve of the declared resistance, insulation and smoke leakage EIS120, EIS90, EIS60, EIS30, should be installed on wall, which was classified as EIS120, EIS90, EIS60, EIS30.

It is allowed to install KTS dampers in wall with other fire-resistance, should be remembered that fire-resistance in this situation is resistance of lowest classified (in this regard) element in this system.

Ducts made of flammable and non-flammable materials can be connected to the damper. Ducts should be installed that they cannot load the damper during fire. Ducts lengthening during fire can be compensated by support and knee.

ATTENTION: Distance between fire dampers or fire damper and construction elements must be compatible with standard 1366-2:

- a. min. 200 [mm] between fire damper, which are installed in different ventilating wires,
- b. min. 75 [mm] between fire damper and construction element (wall/ceiling).

I. INSTALLATION TECHNOLOGY - CEILING

- Make an opening in the ceiling with the 70 [mm] (acceptable $60 \div 100$ [mm]) greater than the nominal dimensions of the damper: DN+70.
- Put the damper into the installation opening and support or suspend it in order to maintain the imposed dimension of the building i.e. the damper embossing must be on boundary of the building, and installation opening axis must coincide with fire damper axis.
- After setting the fire damper as described, mounting the mounting brackets, fill the gap between the fire damper and the ceiling with cement, cement-lime mortar or concrete.
- After drying of the mortar (approx. 48 hours), remove used supports or suspension, check the fire damper correct operation and leave it in fully open position.

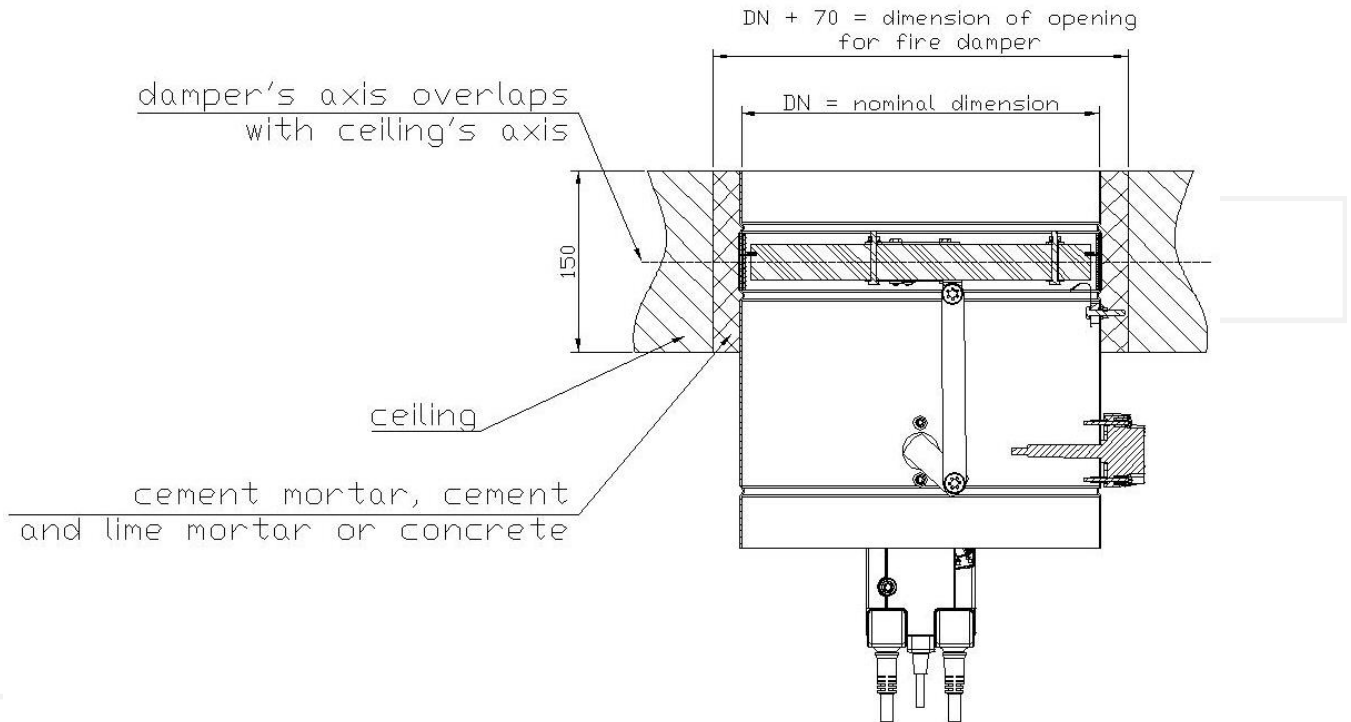

Figure 1. Installation method of fire dampers KTS in ceiling

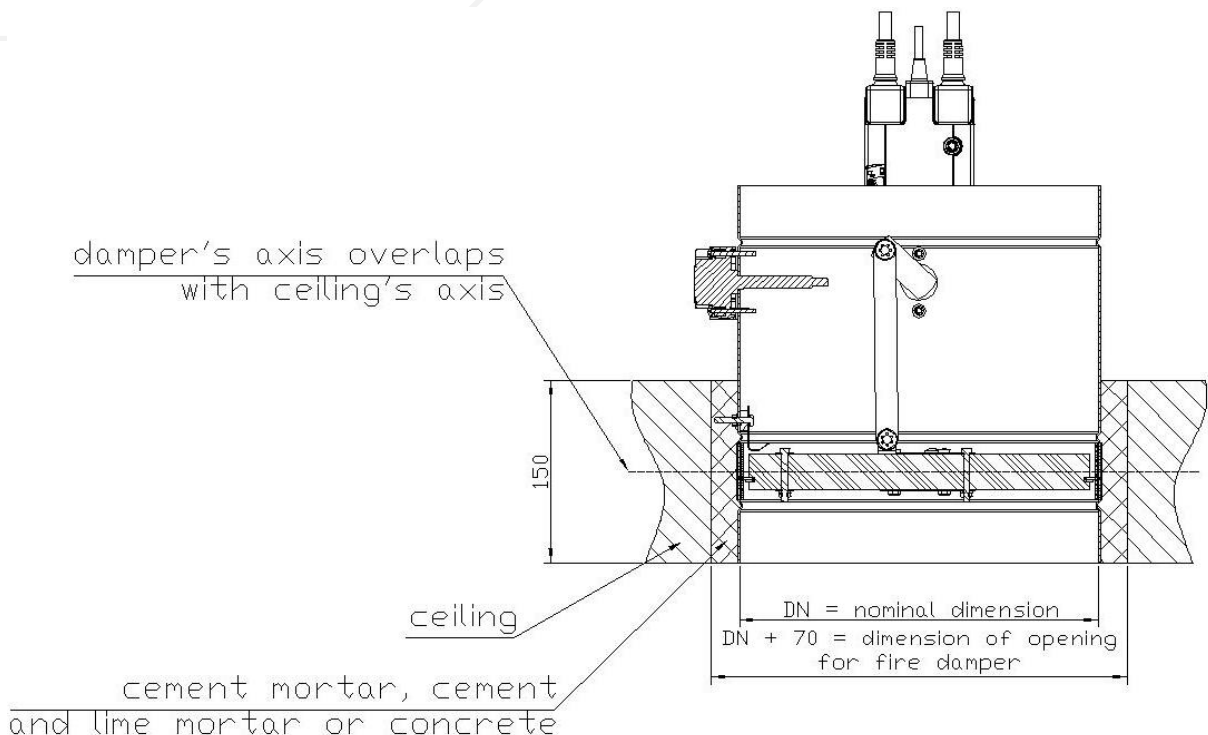

Figure 2. Installation method of fire dampers KTS in ceiling

II. INSTALLATION TECHNOLOGY – RIGID WALL

- a. Make an opening in the wall with the 70 [mm] (acceptable $60 \div 100$ [mm]) greater than the nominal dimensions of the fire damper: DN+70.
- b. Put the damper into the installation opening and support or suspend it in order to maintain the imposed dimension of the building i.e. the damper embossing must be on boundary of the building, and installation opening axis must coincide with fire damper axis.
- c. After setting the fire damper as described, fill the gap between the fire damper and the wall with cement, cement-lime mortar or concrete.
- d. After drying of the mortar (approx. 48 hours), remove used supports or suspensions, check the fire damper correct operation and leave it in fully open position.

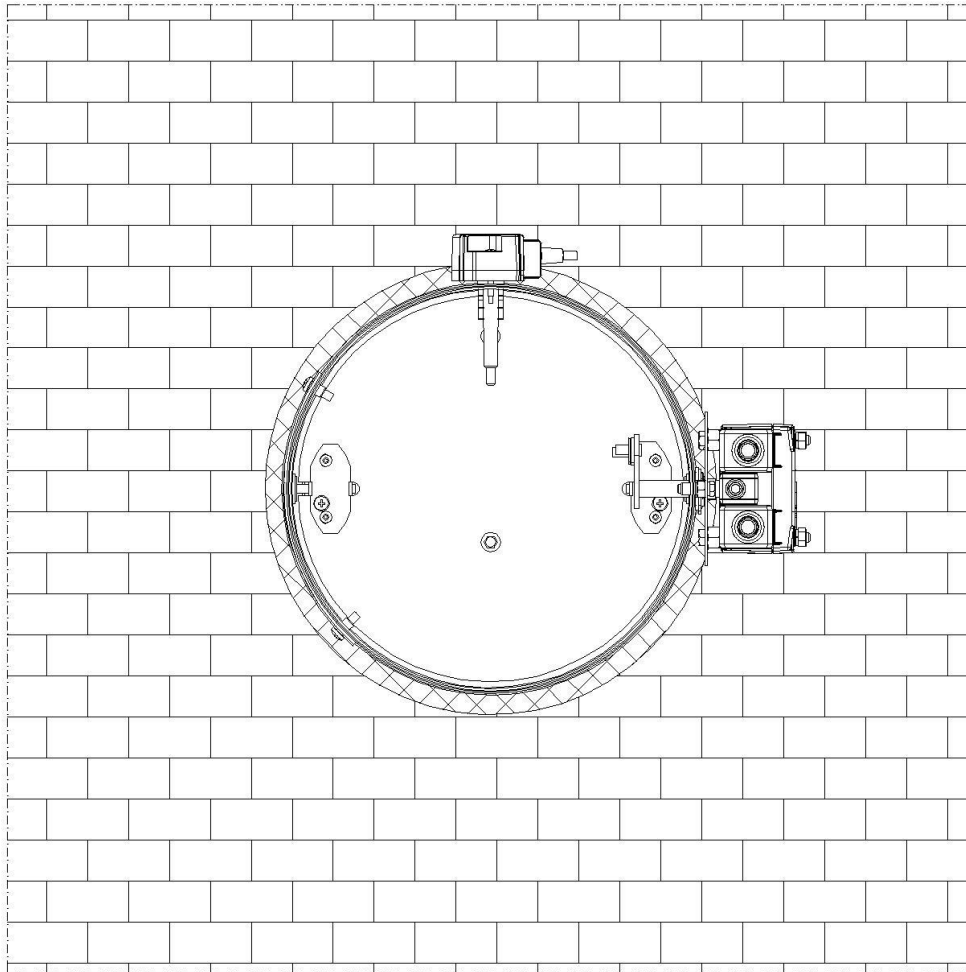

Figure 3. Installation of KTS in rigid wall construction with horizontal axis of rotation of the damper.

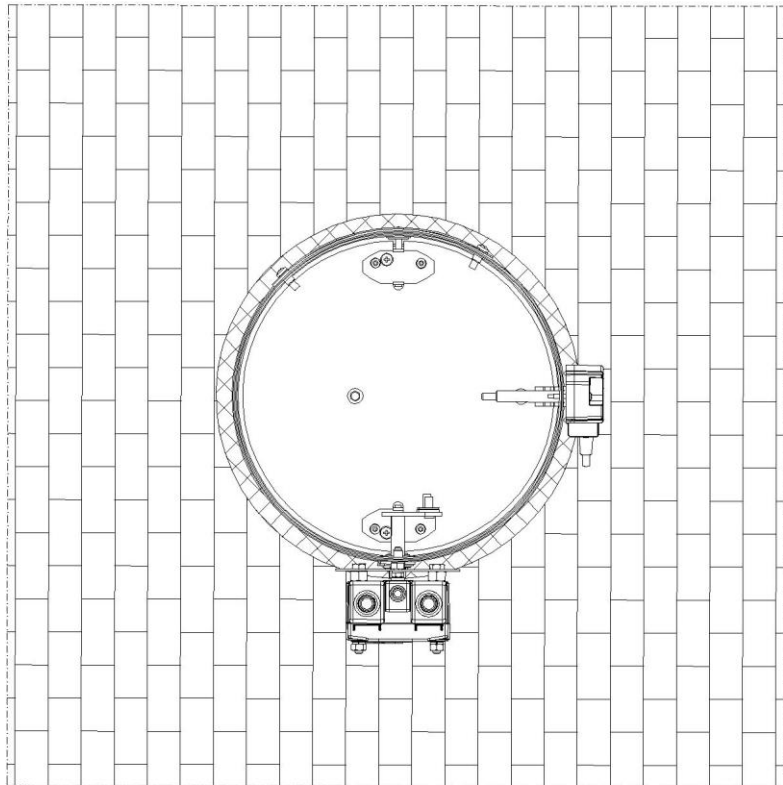

Figure 4. Installation of KTS in rigid wall construction with vertical axis of rotation of the damper.

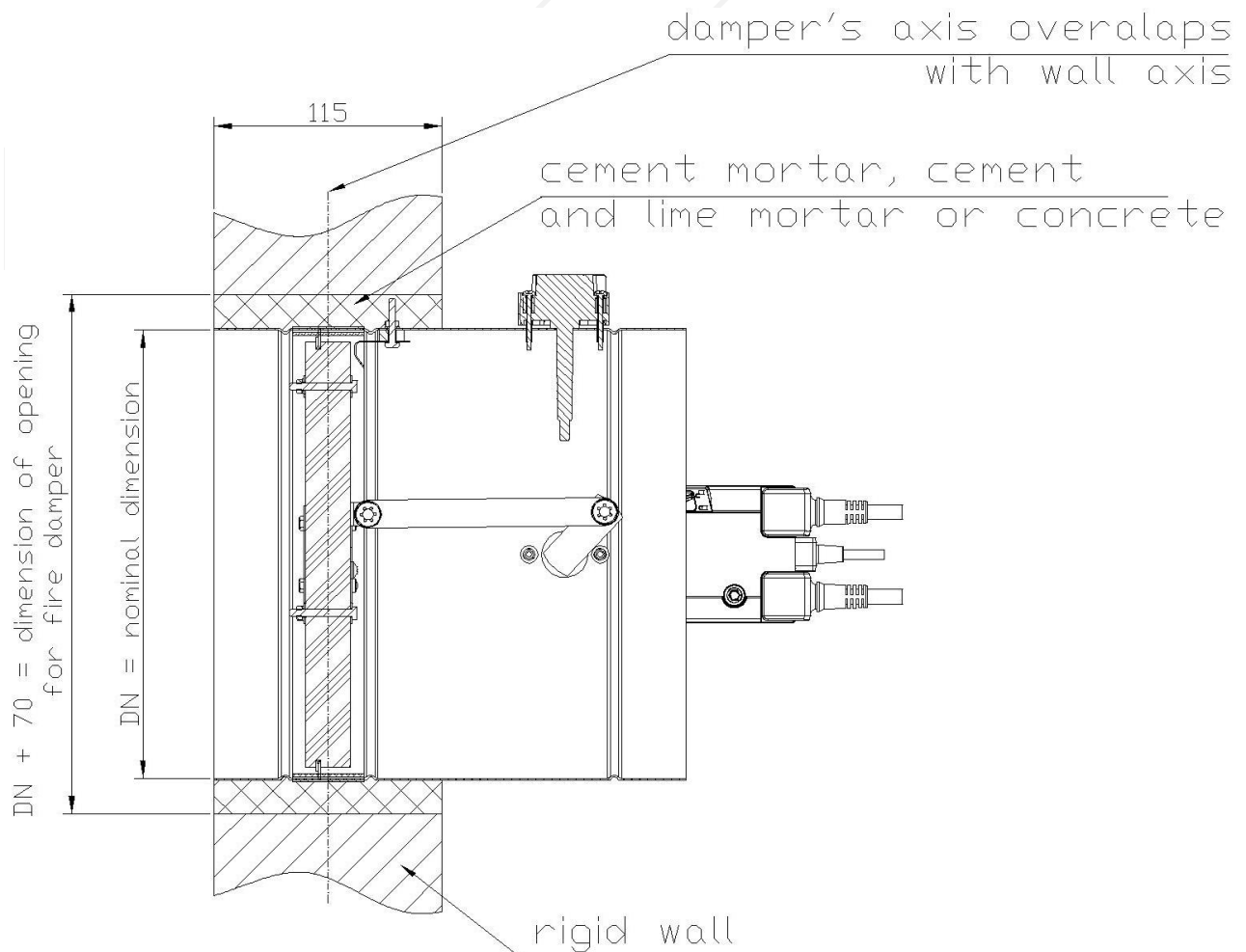

Figure 5. Installation of KTS in rigid wall construction with 115 [mm] wall thickness.

III. INSTALLATION TECHNOLOGY – FLEXIBLE WALL

- Make an opening in the wall with the 70 [mm] (acceptable $60 \div 100$ [mm]) greater than the nominal dimensions of the fire damper: $B=DN+70$ and $H=DN+70$.
- Put the damper into the installation opening and support or suspend it in order to maintain the imposed dimension of the building i.e. the damper embossing must be on boundary of the building, and installation opening axis must coincide with fire damper axis.
- After setting the fire damper as described, fill the gap between the fire damper and the wall with non-flammable mineral wool of high density, 100 kg/m³ or more.
- Seal the place of filling with mineral wool using the sealing compounds: Hilti Firestop Coating CP 673, Promastop-Coating, Promaseal-Mastic or Soudal Firesilicone B1 FR.
- Mount collar, both side of wall, made of GKF boards, 12,5 [mm] thick and $DN+ 350$ [mm] wide, using screws (with the hole for the damper cutted out). For easy assembly, the collar can be made of two parts.
- After mounting the collar, remove the supports or suspensions, check the fire damper correct operation and leave it in open position.

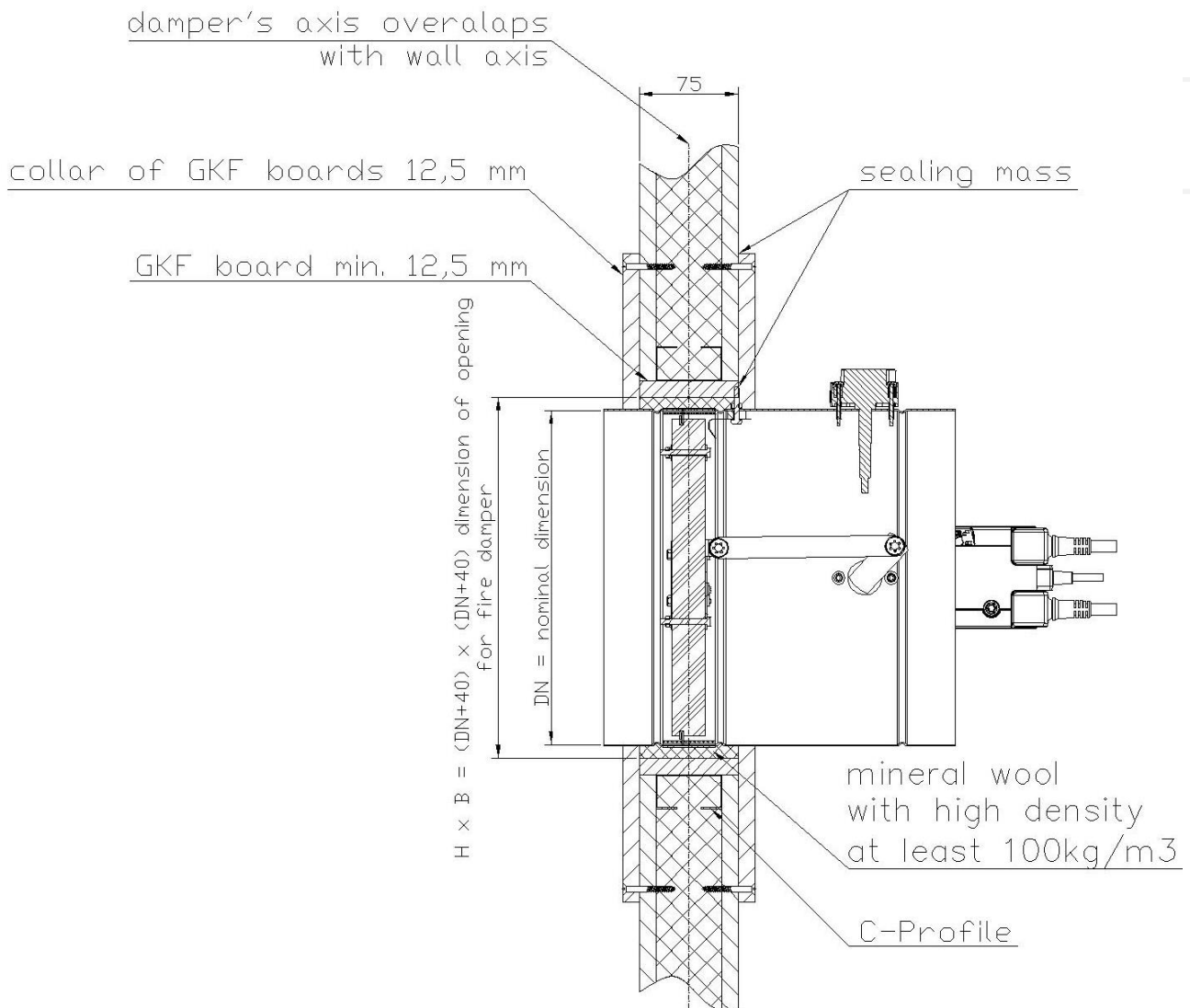

Figure 6. Installation of KTS in flexible wall construction with 75 [mm] thickness

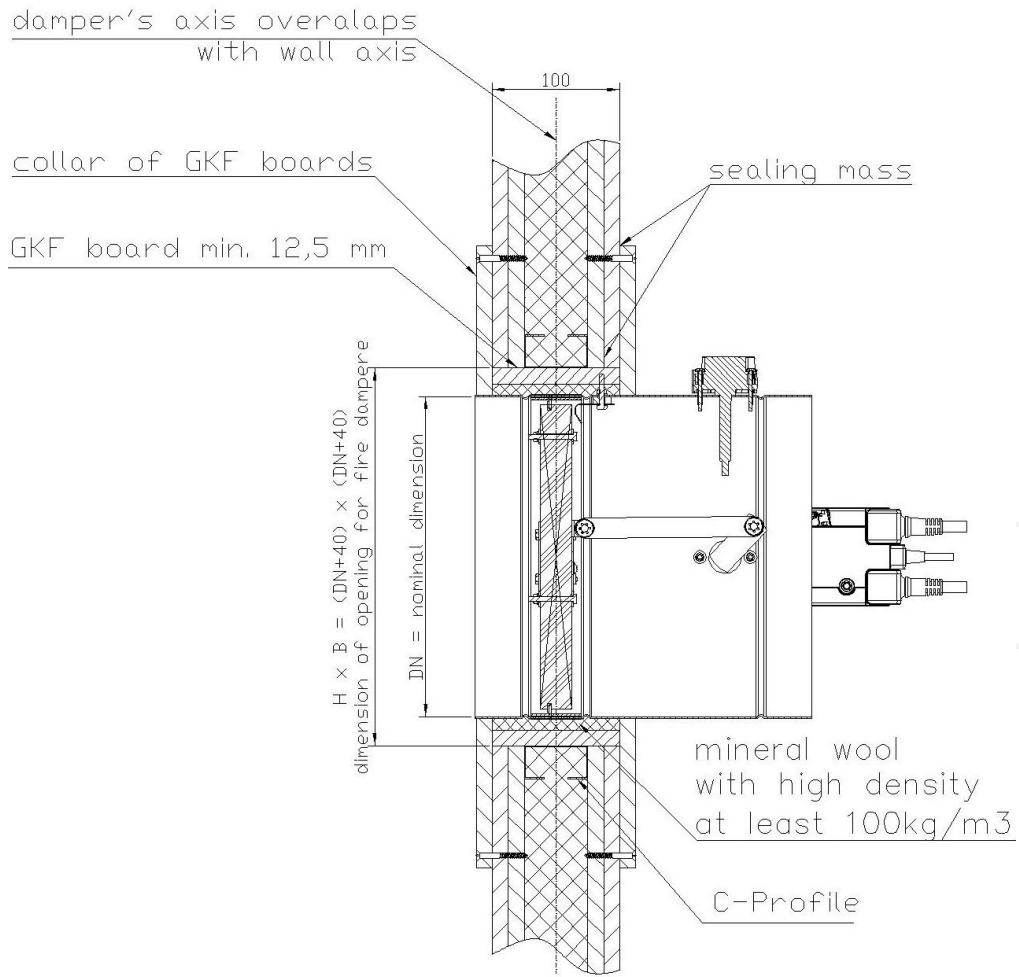

Figure 7. Installation method of fire dampers KTS in flexible wall with 100 mm thickness

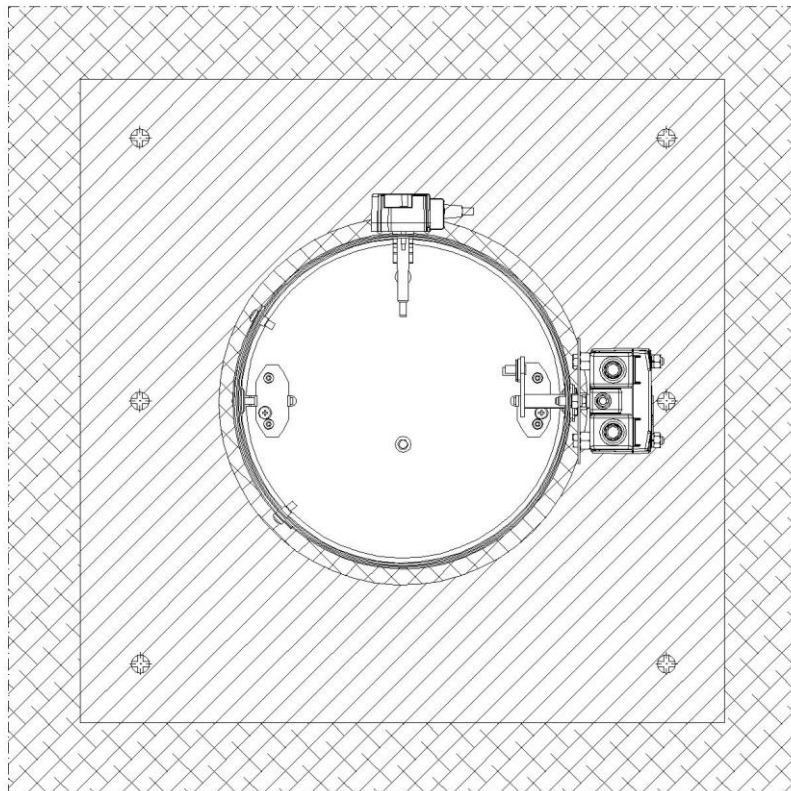

Figure 8. Installation method of fire dampers KTS in flexible wall with horizontal rotation axis of baffle

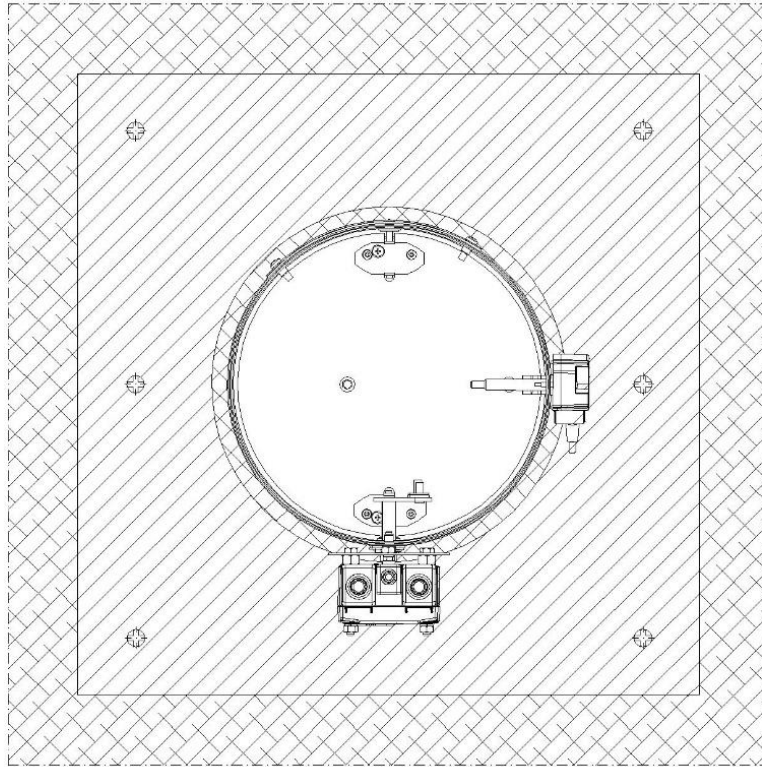

Figure 9. Installation method of fire dampers KTS in flexible wall with vertical rotation axis of baffle

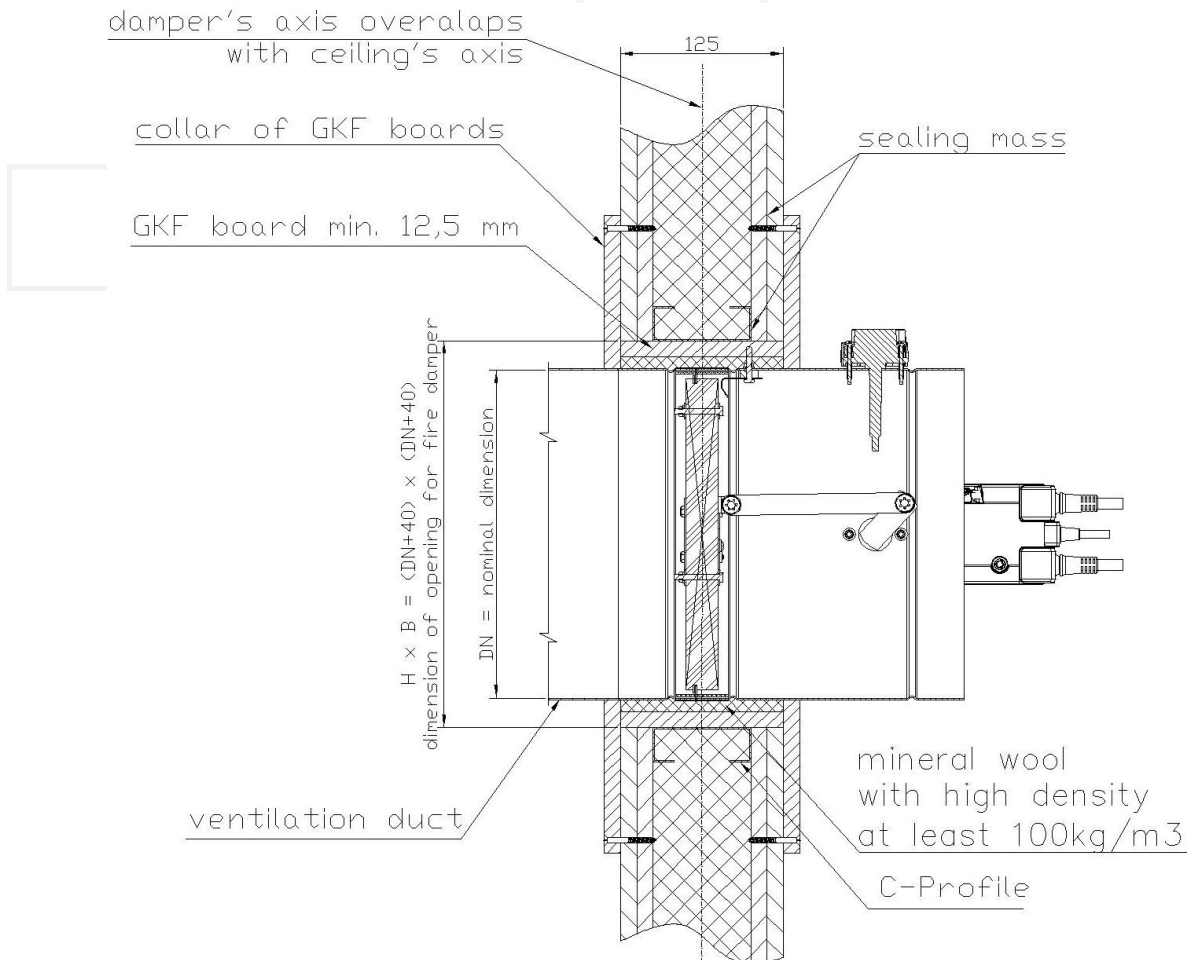

Figure 10. Installation method of fire dampers KTS in flexible wall with 125 [mm] thickness

IV. INSTALLATION TECHNOLOGY – HIGH WALL THICKNESS CONSTRUCTION

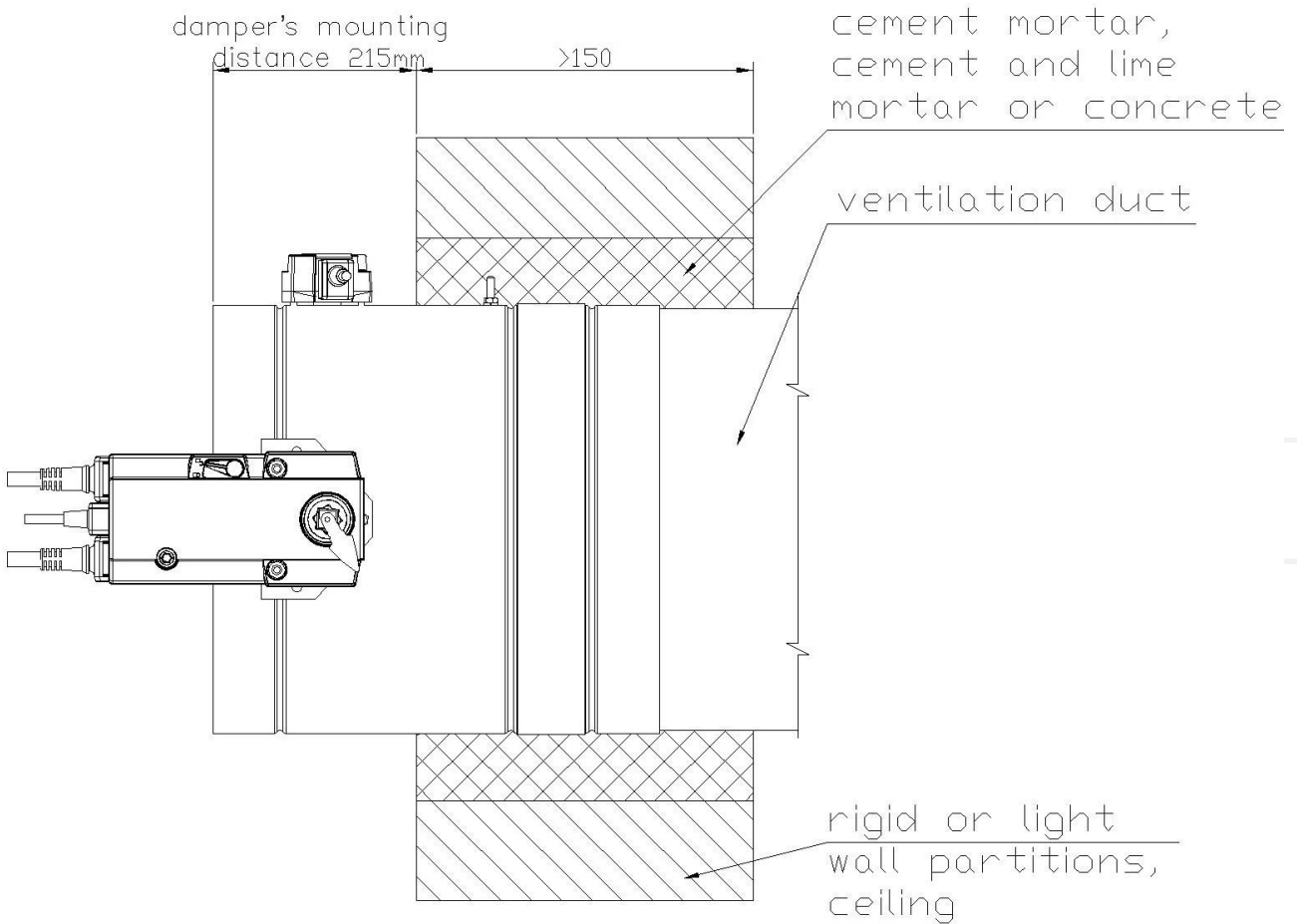

Figure 11. Installation method of fire dampers KTS in high wall thickness constructions

In rigid and flexible wall construction and in ceiling with thickness less or equal to 150 [mm], KTS fire dampers are mounted in such a way that the damper installation limit, i.e. 52 [mm], is maintained and the damper embossing must be on boundary of the building.

Whereas in case of walls and ceilings with thickness higher than 150 [mm]: the KTS fire dampers are mounted in such a way, that the damper installation limit i.e. 215 [mm], is maintained and the damper flange must be on boundary of the building (as in figure 11).

V. INSTALLATION TECHNOLOGY – INSTALLATION AWAY FROM WALL CONSTRUCTION (SILICATE BOARDS)

- Make an opening in the wall with the dimensions 100 [mm] greater than the nominal dimensions of the fire damper, i.e. DN+100.
- Push the ventilation duct into the installation opening and support or suspend it so that the channel and opening alignment are maintained.
- Mount the damper to ventilation duct, additionally support or suspend it.
- On the mineral wool coverage section, apply 1 [mm] PROMASTOP Coating (made by PROMAT) layer.
- The PROMASTOP Coating layer has to be applied on fire barrier in the place where the wool was sealed on both sides, with a size about DN + 300.
- Wrap the ventilation duct and the damper at the appropriate length of mineral wool with high density at least 100 kg/m³.
- When the mineral wool is mounted, check correct functionality of the damper, then leave it in the open position.

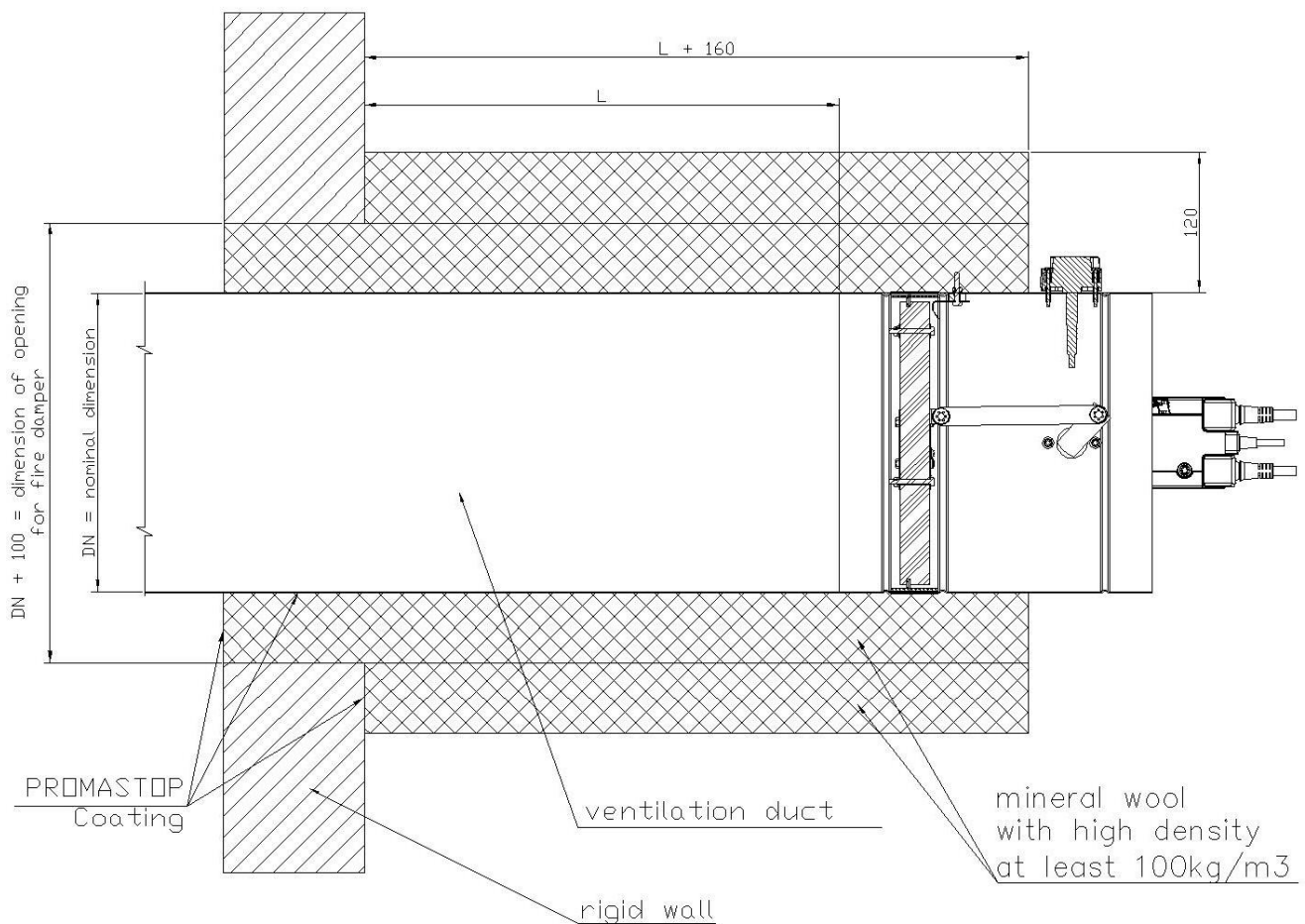

Figure 12. Installation method of fire dampers KTS away from wall constructions